

Highlights of Analytical Sciences in Switzerland

Division of Analytical Sciences

A Division of the Swiss Chemical Society

ReGaS: SI-traceable Reference Mixtures of Reactive Trace Gases Produced by Mobile Generators

Céline Pascale, Daiana Leuenberger, Myriam Guillevic, Andreas Ackermann, and Bernhard Niederhauser*

*Correspondence: B. Niederhauser, Eidgenössisches Institut für Metrologie METAS, Lindenweg 50, CH-3003 Bern-Wabern, E-Mail: bernhard.niederhauser@metas.ch

Keywords: Dynamic generation · Expanded uncertainty · Permeation · Reference gas mixture · SI-traceability

To answer the needs of air quality and climate monitoring networks, three reference gas generators were developed and manufactured at METAS, dynamically producing reference gas mixtures for reactive compounds at atmospheric concentrations which are traceable to the international system of units (SI). These generators (Reactive Gas Standard ReGaS) can be applied for on-site calibrations of instruments in laboratories as well as in air quality monitoring stations. The technical features of the mobile generators allow the realization of such gas standards for reactive compounds (e.g. NO_2 , NH_3 , volatile organic compounds) in the $\text{nmol}\cdot\text{mol}^{-1}$ range (ReGaS1 and ReGaS2), and halogenated gases in the $\text{pmol}\cdot\text{mol}^{-1}$ range (ReGaS3).

The generation method is based on permeation and dynamic dilution. The purpose-built, multi-chamber permeation ovens of generators ReGaS2 and ReGaS3 allow for the generation of mixtures containing up to five different compounds. This mixture is then diluted using thermal mass flow controllers (MFC), thus making the production process easily adaptable to generate the required concentrations. All parts of ReGaS1 and ReGaS2 in contact with the gas mixture have been treated with a silica-based coating to reduce adsorption/desorption processes. Every

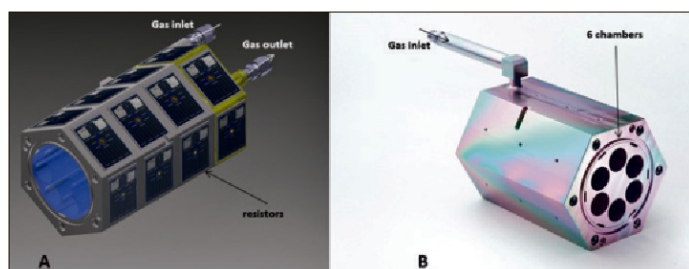

(A) CAD design and (B) picture of the multi-chamber permeation oven in ReGaS2 and ReGaS3 with Silconert2000 coating allowing for the generation of up to five compounds simultaneously.

input parameter relevant for the generation of the reference gas mixtures is calibrated with traceable standards at METAS. Therefore the molar fraction of the reference gas mixture with its associated uncertainty is traceable to the SI.

The stability and reproducibility of the generated amount fractions were tested with NH_3 for ReGaS1, NO_2 for ReGaS2 and HFC-125 for ReGaS3. They demonstrate stability over days better than 0.2%, 0.4% and 0.8%, respectively, and reproducibility better than 0.5%, 0.7% and 1%, respectively. Finally, depending on the analyte and concentration, the relative expanded uncertainty of the generated concentration is between 1.5% and 4% with the major contributions coming from the uncertainty of the permeation rate and/or of the purity of the matrix gas.

The reference gas mixtures can be used on-site for the calibration of measurement instruments at the relevant atmospheric amount fractions. The relative expanded uncertainties are sufficiently low for distinguishing long-term atmospheric trends recorded with high-resolution and high-precision instrumentation.

Received: September 11, 2017

Reference

C. Pascale, M. Guillevic, A. Ackermann, D. Leuenberger, B. Niederhauser, *Meas. Sci. Technol.* **2017**, in press: <https://doi.org/10.1088/1361-6501/aa870c>

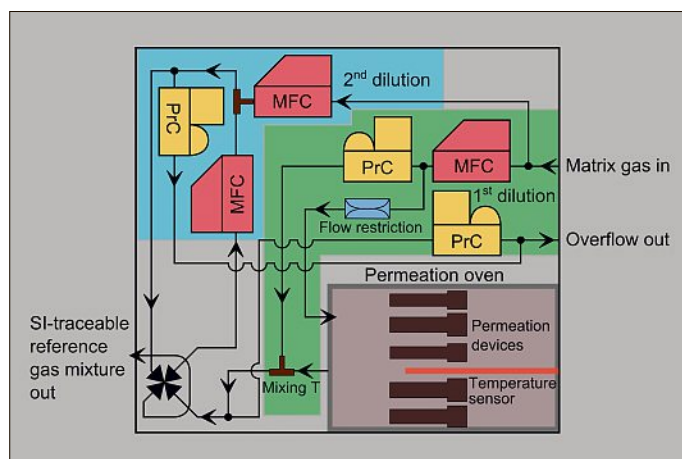

Scheme of ReGaS3. ReGaS3 has two dilution steps and a multi-chamber permeation oven for the generation of halogenated compounds at pmol/mol level. (MFC: mass flow control, PrC: pressure control.)

Can you show us your analytical highlight?

Please contact: Dr. Veronika R. Meyer, Unterstrasse 58, CH-9000 St. Gallen
Tel.: +41 71 222 16 81, E-mail: VRMeyer@bluewin.ch